

Easter Island Moai 4' Climber



While climbing structures are often a main attraction at the playground, the Easter Island Moai 4' Climber is a head above the rest. The Easter Island Moai is designed for a captivating play experience that is also educational. This 4 foot climber is an awesome play feature for any playground, park or Archaeological Adventure theme play center. Indoor or outdoor, the playground with a unique and exciting climber like the Moai climber is going to be a regular stop on a kid's play schedule. Boosting balancing and coordination skills, the climber experience also fuels a developing imagination, but for a kid, it boils down to the fact that "It's fun!"

The 4 Kids was born out of a desire to create high quality, one-of-a-kind park shelters and play environments that effectively appeal to children's natural curiosity and imagination.

All of our products are custom designed to work perfectly with your unique playground. Let us know how we can meet your specific needs by contacting our knowledgeable design specialists, today.

Contact Us

Ordering from The 4 Kids is easy, initial consultation & quote is free.
We can also provide you with design ideas and conceptual drawings.
We want your whole experience with The 4 Kids to be smooth & rewarding.

4400 Oneal St. Greenville, TX 75401

903.454.9237

info@the4kids.com

www.the4kids.com

Why Use Us?

Let our team of experienced engineers and artists make your playground the destination for fun! We can create an exciting space where children's imaginations can run wild. A playscape where parents can feel secure and create lasting memories with their whole family.

Key Features

- Designed for children from 2 to 12
- Four finishes to choose from
- Artistic and exciting design
- Custom made to satisfy
- Free initial quote



Specifications

Age Range:

2 -5 years
5 - 12 years

Dimensions:

59" X 36.5" X 46"

Play Area:

17' X 15'

Mounting Options:

See Typical
Installation Details



Contact Us

Ordering from The 4 Kids is easy, initial consultation & quote is free. We can also provide you with design ideas and conceptual drawings. We want your whole experience with The 4 Kids to be smooth & rewarding.

4400 Oneal St. Greenville, TX 75401

903.454.9237

info@the4kids.com

www.the4kids.com

© 2014 The 4 Kids Inc. All rights reserved.



MOAI CLIMBER

5'11" L x 3' 1/2" W x 3'10" H

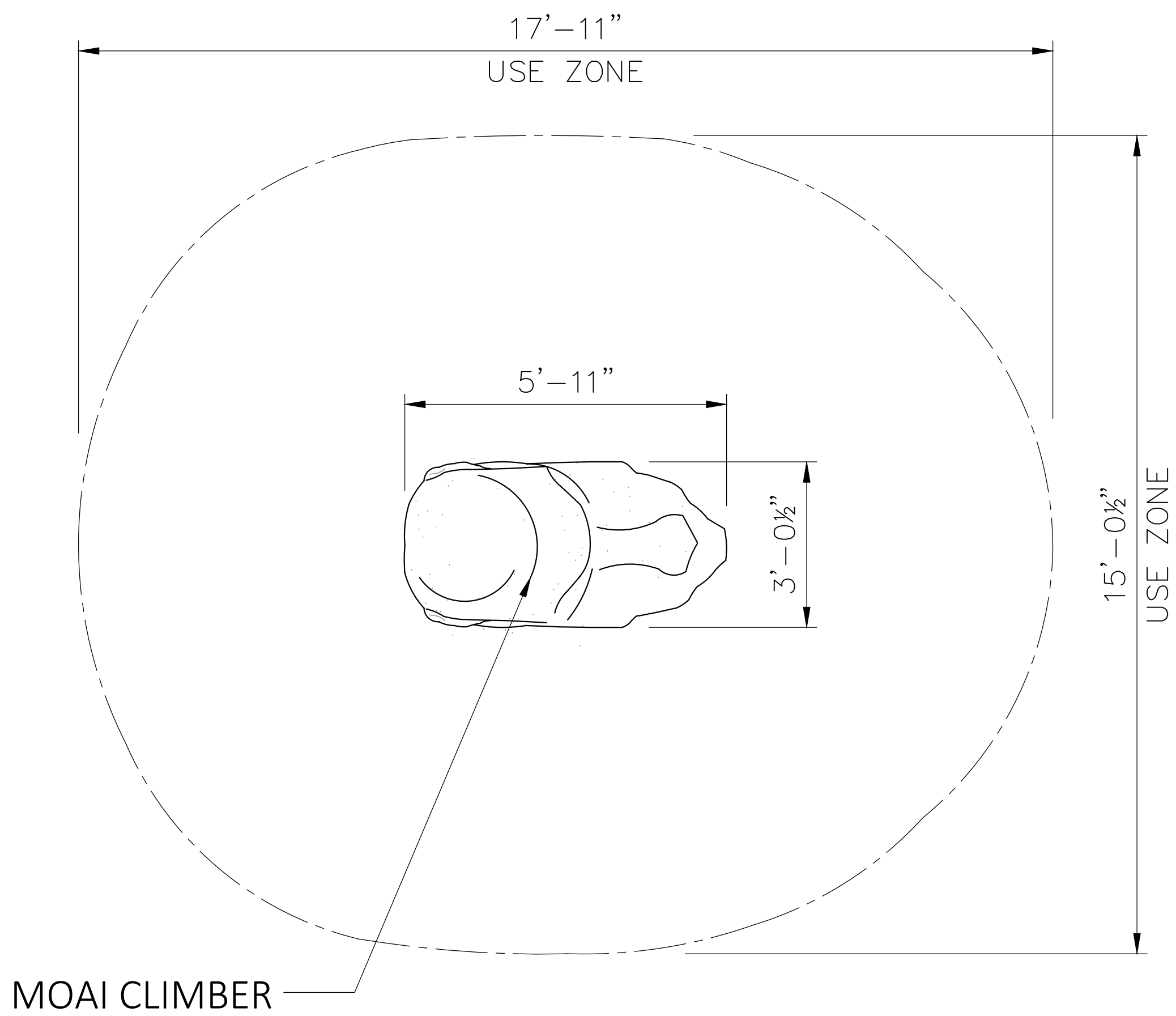

TOP VIEW

SCALE: 1/2" = 1'