



Toucan Post Topper



A friendly toucan perched on a theme park utility post can accomplish a multitude of park tasks, like welcoming park goers at entrances, lining pathways and holding directional signs, or even pointing the way to fun rides or dining centers. The 4 Kids Toucan Post Topper is a high quality, meticulous replica of the real thing, catching the eye and captivating the imagination of everyone who encounters this fascinating bird. Posed in a stately stance, perched atop a post, the toucan is so lifelike that observers are tempted to touch, just to see if he's real. Bringing a new level of whimsy and fun to every location, the possibilities are endless for placement of post toppers such as the toucan, in parks, indoor and outdoor play centers, museums, aviaries, family resorts and many more. Crafted with impeccable artistry, the toucan also has a high quality finish that resists damage in all kinds of weather, even sea salt spray, ice, snow or intense heat. Virtually maintenance free, The 4 Kids Toucan Post Topper is certain to look beautiful for years of service.

The 4 Kids was born out of a desire to create high quality, one-of-a-kind park shelters and play environments that effectively appeal to children's natural curiosity and imagination.

All of our products are custom designed to work perfectly with your unique playground. Let us know how we can meet your specific needs by contacting our knowledgeable design specialists, today.

Contact Us

Ordering from The 4 Kids is easy, initial consultation & quote is free.
We can also provide you with design ideas and conceptual drawings.
We want your whole experience with The 4 Kids to be smooth & rewarding.

4400 Oneal St. Greenville, TX 75401

903.454.9237

info@the4kids.com

www.the4kids.com

Why Use Us?

Let our team of experienced engineers and artists make your playground the destination for fun! We can create an exciting space where children's imaginations can run wild. A playscape where parents can feel secure and create lasting memories with their whole family.

Key Features

- Customized playground designs
- American made in Greenville, Texas
- High quality and low maintenance
- Lifelike design that mesmerizes
- Expert team of designers and artists



Specifications

Age Range:
N/A

Dimensions:
26"L x 19"W x
Post Height

Use Zone:
N/A

Mounting Options:
See Typical
Installation Details

Contact Us

Ordering from The 4 Kids is easy, initial consultation & quote is free. We can also provide you with design ideas and conceptual drawings. We want your whole experience with The 4 Kids to be smooth & rewarding.

4400 Oneal St. Greenville, TX 75401

903.454.9237

info@the4kids.com

www.the4kids.com

© 2014 The 4 Kids Inc. All rights reserved.

TOUCAN POST TOPPER

19" X 26" X POST HEIGHT

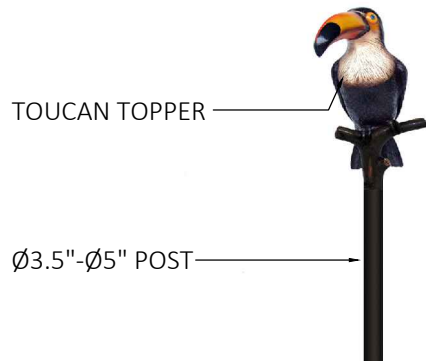

PRODUCT VIEW

SCALE: NTS

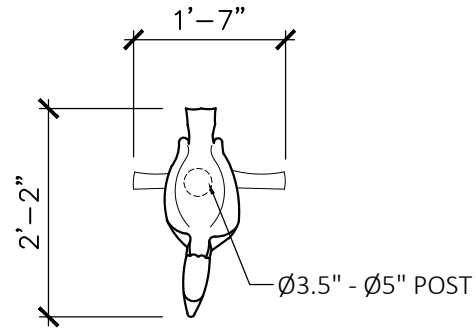

TOP VIEW

SCALE: 1/2" = 1'

ALL RIGHTS RESERVED. THIS DRAWING IS PROPERTY OF THE 4 KIDS INC. AND MAY BE USED ONLY WHEN UTILIZING THE 4 KIDS INC. GENERAL TERMS AND CONDITIONS APPLY AND ARE INCORPORATED HERE IN BY REFERENCE. THIS DETAIL MAY NOT APPLY TO ALL CONDITIONS AND CONSTRUCTION SITUATIONS.

ITEM ID: POS174

MATERIAL:

MOLD

APX. TTL. WEIGHT

TOTAL # OF ITEM:

- LBS.[- KG]

TOTAL SQ. FEET: - [- sqm.]

PROJECT:

TITLE: TOUCAN POST TOPPER

REFERENCES:

COLOR & PER APPROVED SAMPLE
TEXTURE: PER APPROVED SAMPLE



CUSTOM THEMED PLAYGROUNDS

4400 ONEAL STREET, GREENVILLE, TX 75402 PHONE 903.454.9237 FAX 903.454.3642

TYPE DWG:

DRAWN BY: ABS

DATE:

SCALE: AS NOTED

SHEET:

DWG. SHEET: